

# Stacking Shipping Containers on Land for an Off-Axis Detector

J. Cooper, J. Kilmer, B. Wands  
Fermi National Accelerator Laboratory, Batavia, IL 60510

(May 29, 2003)

## Introduction

Fig. 1 shows a typical International Standards Organization (ISO) Series 1 shipping container.

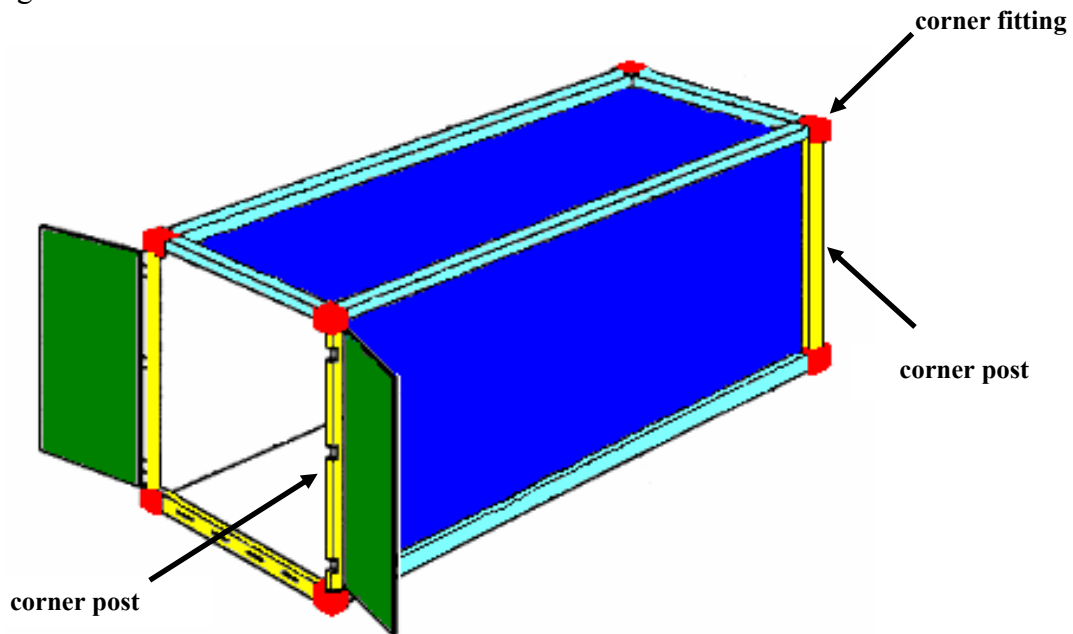

**Figure 1. ISO Series 1 Shipping Container**

These containers are designed to make vertical contact with each other through discrete corner fittings; when stacked, all vertical force is transferred through these fittings, in turn loading the corner posts, and not the walls, of the container. The number of containers which can be stacked on each other is determined by the strength of the corner posts.

ISO Standard 1496<sup>(1)</sup> states that the corner posts of ISO Series 1 containers should be tested to a load of 86,400 kg (190,480 lbs). This is the load applied to the posts of the bottom container in an 8-on-1 stack of 24,000 kg (gross weight) containers,

multiplied by a factor of 1.8. This extra factor is used to take into account “conditions aboard ship and the relative eccentricities between superimposed containers.”<sup>(1)</sup> The “conditions aboard ship” were derived from a 1964 study of maximum acceleration values under the worst sea and wind conditions.<sup>(2)</sup>

Calculating the safe stacking height for loaded containers *on land* requires some understanding of the corner posts, their material properties, possible failure modes, and what constitutes an adequate factor of safety.

### **Corner Post Geometry and Compressive Load-Bearing Capacity**

Corner post steels typically correspond to the specification ASTM A-572, with a yield stress of 47,000 psi, and an ultimate stress of 70,000 psi. This is a low alloy columbium or vanadium steel commonly used for high-strength steel weldments, such as bridges. The load-bearing characteristics of corners posts are complex, because in a walled container the posts receive substantial lateral stability, and compressive cross sectional area, from the participation of the walls and doors.

The corner post can fail in two ways: The first is collapse, or buckling. This occurs in a slender column when the compressive load reaches a critical load  $P_{cr}$  which is so large that the column can no longer recover from small lateral displacements along its length. The result is sudden and catastrophic loss of stiffness, and gross deformation of the column and its attached material.

A second type of failure can occur if the compressive load  $P_{comp}$  exceeds the value  $S_y A$ , where  $S_y$  is the yield stress of the material, and  $A$  is the cross sectional area of the post. Even a column which is stable against buckling failure can fail from compressive yielding. Failures of this type are rare for columns, since the yielding will tend to produce larger cross sectional area through plastic deformation, and eventually become self-limiting. This self-limit may not be reached before even a very short column becomes unstable, however, resulting in a type of collapse that is characterized by large amounts of plastic deformation.

The most likely failure mode, given the substantial lateral constraint offered by the walls, is probably a combination of collapse and gross yielding, a type of failure referred to as elastic/plastic collapse.

The calculation of collapse (buckling) loads for long, slender steel columns uses the Euler equation:

$$P_{cr} = k\pi^2 EI/L^2$$

where  $P_{cr}$  = critical (collapse) load

$E$  = modulus of elasticity of steel = 30e6 psi

$I$  = minimum moment of inertia of section

$L$  = length of column

$k$  = factor for end rotational restraint (theoretical range from 1-4)

For the corner posts, the degree of end rotational restraint is difficult to quantify. The top, bottom, and side rails will serve to provide substantial restraint, and even the corner fitting contact of the loading container above a corner post will tend to limit rotation. Therefore, a  $k$  factor of 2 is chosen for calculating the estimates of collapse load.<sup>(3)</sup> This is less than the complete rotational restraint ( $k = 4$ ), but greater than free rotation ( $k = 1$ ).

In addition to resisting collapse, the corner post must also work at a compressive stress that is below the yield of the material. Corner posts will yield at a stress of 47,000 psi. Therefore, the minimum cross sectional area for resisting the corner post loads is  $A = 190,840/47,000 = 4.05 \text{ in}^2$ .

While the minimum performance of a corner post is standardized via ISO, the actual geometry of the post is not. Manufacturers have explored many different designs for many different types of containers, all of which will pass the ISO test load of 86,400 kg or 190,840 pounds. Figure 2 shows the most common corner post cross-sections at the door and walled ends of a Series 1 container. These posts are made of 6mm thick pressed steel shapes welded together along the length of the post. In the case of the door end post, a piece of hot rolled channel 113 x 40 x 10 mm is welded to the 6mm plate. Both posts in Figure 2 have adequate cross sectional area from the standpoint of compressive stress. However, the Door End post (a), has a collapse load which is less than the load required by the ISO standard, and therefore must rely on interaction with the walls and doors of the container to produce the necessary load-bearing capacity.

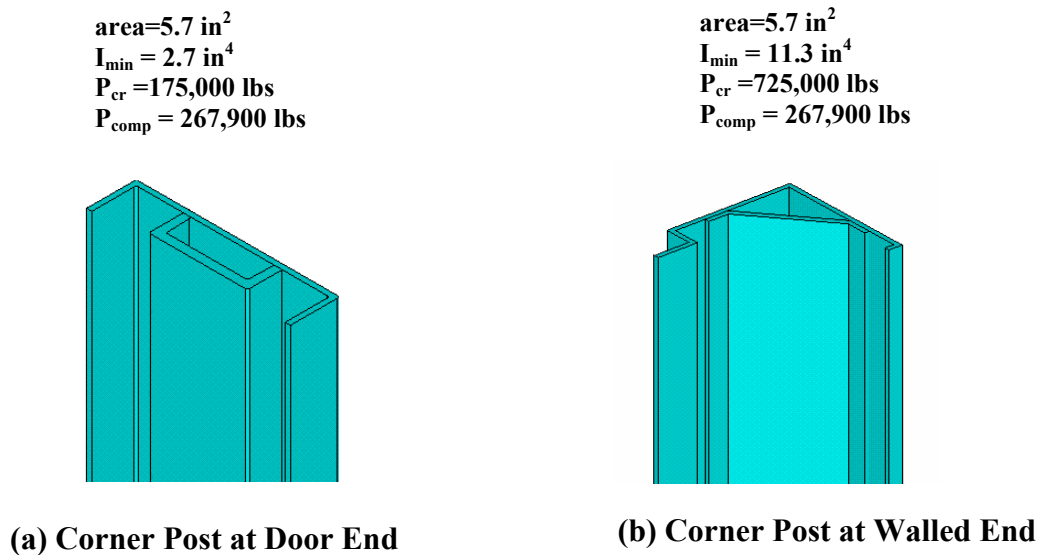

**Figure 2. Corner Post Cross Sections -- Properties and Load Capacities without Wall/Door Participation**

The effect of participation of the walls and doors is illustrated in Fig. 3 The profile of Fig. 2(a) has been used with a 3-inch wide strip of adjacent container sidewall (3.6 mm thick) and a 2-inch wide strip of door panel (2 mm thick), to form a column of considerably higher strength than the profile of Fig. 2(a) alone. The cross section shown, with walls, has a critical load of approximately 252,000 lbs, which is well above the 175,000 lbs of the corner post alone, and well above the 190,480 lbs required by the ISO Standard.

These calculations show that the door is an important part of the load path under stacking, providing additional cross-sectional area for compression and stability. The door also acts as a shear wall, preventing the parallelogram deformation of the end referred to as “racking” or “sideways.” For these reasons, in commercial practice, the doors on a container within a stack are presumably never opened. This is not a constraint on the way the containers are used in commerce, since only one container at a time is loaded or unloaded at terminals, with stacking occurring only during transit.

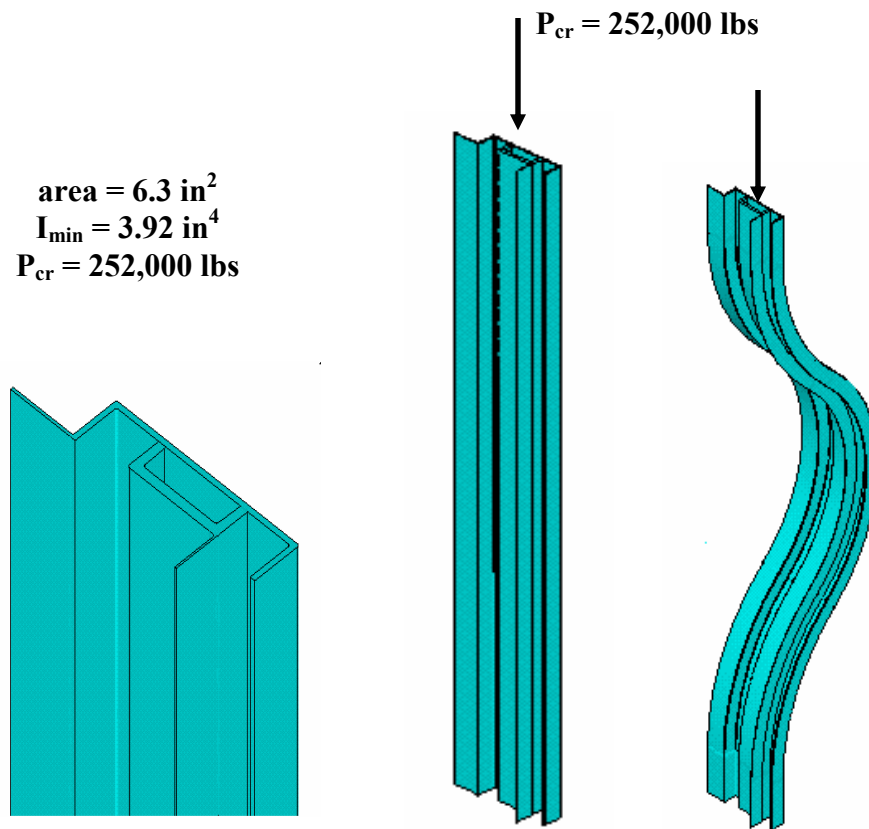

**Figure 3. Corner Post from Fig. 2(a) showing increase in buckling strength due to participation of wall**

## Corner Fittings

The corner fittings shown in Figure 1 are an integral part of the load-bearing column in the container. ISO 1161-1984(E)<sup>(4)</sup> states “Corner fittings for Series 1 freight containers shall be capable of withstanding the loads calculated in accordance with the requirements of ISO 1496/1 for Series 1 containers.” This means that the bottom corner fitting of the bottom container in a stack must withstand the weight of the containers stacked above it, plus the weight of the bottom container itself. The maximum load which a single corner fitting must take is then

$$P_{\text{tot}} = 190,480 + (52,800/4) = 203,680 \text{ lbs}$$

A typical corner fitting is shown in Fig. 4.. The cross sectional area of this fitting is shown in Fig. 5. The total cross sectional area available for compression is  $10.15 \text{ in}^2$ . This results in an average compressive stress under maximum load of 20,067 psi.

Corner fittings are typically cast and machined from A-216 steel, which has a minimum specified yield stress of 40,000 psi. Therefore, under maximum load, a corner fitting of the cross section shown below operates with a safety factor on yield of nearly 2.0



**Figure 4. Corner Fitting**

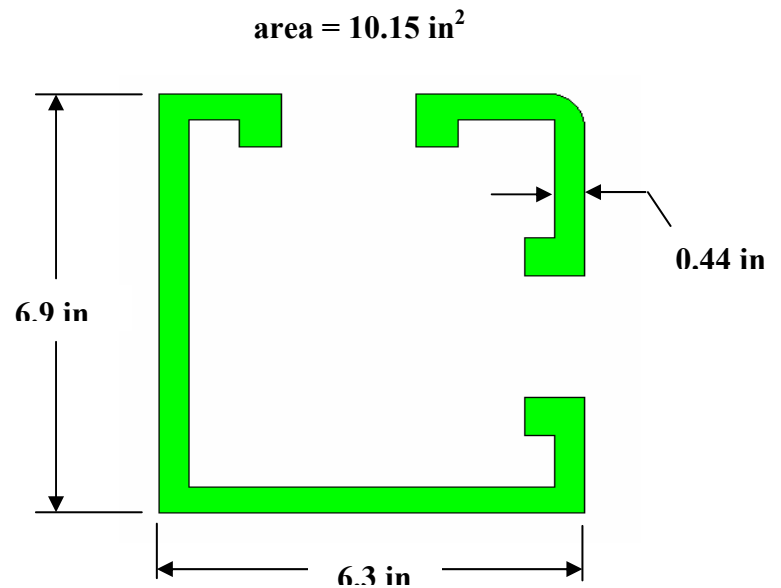

**Figure 5. Fitting Cross Section**

## Safety Factor for Stacking Containers on Land

A safety factor for the corner posts in the bottom container of a stack can be defined as

$$SF = F_{cp-fail}/F_{cp-act}$$

where SF = safety factor

$F_{cp-act}$  = actual operating load on corner post

$F_{cp-fail}$  = failure load of corner post

The ISO Standard, however, does not define a force  $F_{cp-fail}$ ; rather, it specifies the load that each corner post must withstand *without* failure. In this sense, the specified load is a *proof* load,  $F_{cp\_proof}$ , which is simply a load which each corner post must be shown capable of resisting. For the purposes of calculating a safety factor, the specified test load can be thought of as an absolute lower limit on the failure load. Any safety factor calculated with  $F_{cp-fail} = F_{cp\_proof}$  will be smaller than the actual safety factor, since  $F_{cp\_proof}$  is always smaller than  $F_{cp-fail}$ .

Using the expression above, the safety factor of an 8-on-1 stack of containers on land is at least 1.8. Safety factors in engineering commonly range from 1.25 to 2.0 or greater, depending on the amount of confidence the designer has in material performance and load characterization. The AISC Steel Construction Code<sup>(5)</sup>, for example, uses a safety factor of 2 for column loading; however, conservative design in civil structures is necessary because there is typically no load-testing of the parts; they are designed, manufactured, and set in place with only the calculation and fabrication standards serving as proof of merit. Aircraft design, however, uses safety factors closer to 1.25, due to the great penalties incurred by excess weight. The extremely rigorous materials and testing programs common in the aviation industry justify these smaller safety factors.

Because the corner posts of all containers are known to have been tested to the load stipulated by ISO 1496 with no failures occurring at a load that is less than the test load, a safety factor of about 1.5 is adequate for a stack of containers on land. Table I shows the safety factor on the corner post loading of the bottom container in a stack, for stacks of various heights. This table is based on the application of the equation for safety factor, with  $F_{cp-fail} = F_{cp-proof} = 190,480$  lbs, and containers of 52,910 lbs gross weight:

**Table I. Safety Factors on Land for Various Stack Heights on Land  
with Container Corner Post Capacity of 190,480 lbs (86,400 kg)**

<b>Number of Containers Stacked on One</b>	<b>Total Height of Stack</b>	<b>Safety Factor on Corner Post Loading</b>
<b>8</b>	<b>9</b>	<b>1.80</b>
<b>9</b>	<b>10</b>	<b>1.60</b>
<b>10</b>	<b>11</b>	<b>1.44</b>
<b>11</b>	<b>12</b>	<b>1.31</b>

The table shows that we can stack 9-on-1 on land, and maintain a safety factor of greater than 1.5.

**Possible Modifications**

For a final detector design, good engineering practice would require that the corner posts of several containers be loaded to failure to more precisely determine  $F_{cp\_fail}$ , from which more accurate stacking safety factors could be calculated. Some advantage might be taken of the fact that while  $F_{cp\_fail}$  is not known, it is certainly higher than 190,480 lbs (86,400 kg). If the measured failure load is just 4% higher than the test (proof) load, the safety factor on a 10-on-1 stack becomes 1.5, and stacking to that height becomes defensible.

Some vendors advertise containers with a higher capacity<sup>(6)</sup> than the ISO Series 1 standard, and advantage could be taken of the greater payload, as well as the higher post strength, in configuring the detector array. The typical higher post rating quoted is 214,290 lbs (97,400 kg), allowing exactly 9 on 1 stacking of 52,910 lb (24,000 kg) containers at sea and therefore allowing 10 on 1 on land with a safety factor of  $(9/8) \cdot (1.44) = 1.62$ .

Similarly, if the Off-Axis detector density is small enough that our standard gross weight container is less than 52,910 lbs (24,000 kg), then even higher stacks could be supported. Table II shows the stack heights possible when the higher strength containers are used. A container volume of 33.2 m<sup>3</sup> is assumed with a tare weight of 2,250 kg and four different detector gross weights of 22,150 kg, 24,000 kg, 26,000 kg and 30,480 kg. The 30,480 kg number is the vendor quoted maximum gross weight for the higher strength containers. Comparing Tables I and II shows that the higher strength posts lead to the same height stacks as the lower strength posts for containers of density 0.75 gm/cc vs. 0.66 gm/cc.

**Table II. Stack Heights on Land for Various Detector Densities with Container Corner Post Capacity of 214,290 lbs (97,400 kg)**

Number of Containers Stacked on One	Total Height of Stack (m)	Safety Factor on Corner Post Loading			
		with payload density = 0.60 g/cc (22,150 kg gross)	with payload density = 0.66 g/cc (24,000 kg gross)	with payload density = 0.75 g/cc (27,150 kg gross)	with payload density = 0.85 g/cc (30,480 kg gross)
8 on 1	23.3	2.20	2.03	1.80	1.60
9 on 1	25.9	1.95	1.80	1.59	1.42
10 on 1	28.5	1.76	1.62	1.43	1.28
11 on 1	31.1	1.60	1.48	1.30	1.16

## **Conclusion**

Stacking ISO containers 10 high on land is reasonable, and stacks as high as 12 may be possible depending on the type of container purchased and on the loading of the container with Off-Axis detector elements. For a final detector design, good engineering practice would require that the corner posts of the selected containers be loaded to failure to more accurately determine the safety factor of the stacked array.



## References

1. ISO 1496-1:1990 *Series 1 freight containers – Specification and testing – Part 1: General cargo containers for general purposes*
2. ISO/TR 15070:1996(E) *Series 1 freight containers – Rationale for structural test criteria*
3. “Commentary on the Specification for the Design, Fabrication and Erection of Structural Steel for Buildings”, Section 1.8, American Institute of Steel Construction, 1978
4. ISO 1161-1984(E) *Series 1 freight containers – Corner fittings – Specification*
5. “Commentary on the Specification for the Design, Fabrication and Erection of Structural Steel for Buildings”, Section 1.5.1.3, American Institute of Steel Construction, 1978
6. We have several specification documents from container vendors that stipulate a higher load capacity, but no details on just how this is accomplished by any container manufacturer via changes in the post configuration. We suspect that these vendors may just be taking advantage of a specification requiring a higher measured failure load as discussed in the preceding paragraph. After all, our post calculations for Figures 2(b) and Figure 3 indicate that these “standard” posts should easily pass a failure load test at 214,290 lbs vs. the original ISO test at 190,480 lbs.